

How to wet a membrane

Wetting of Membrane Filters

To achieve thorough wetting and to ensure an adequate diffusion rate for testing, 60% Isopropyl alcohol (IPA) and 40% water solution should be used. A simple dip in the test solution prior to testing is often sufficient. This can be achieved by allowing the (DRY) filter cartridge to fall slowly, vertically and open end up, in a container of test liquid – see fig 1.

If the cartridge subsequently fails a test inadequate cartridge wetting may be suspected and the cartridge should be re-tested by flowing the test liquid through the cartridge. This can be achieved by attaching the cartridge outlet to a vacuum flask. Immersing the cartridge in the test solution and drawing one litre or more of the test solution through each 254 module until the level of the solvent reaches the top of the cartridge. Do not allow the level to drop below the top of the cartridge.

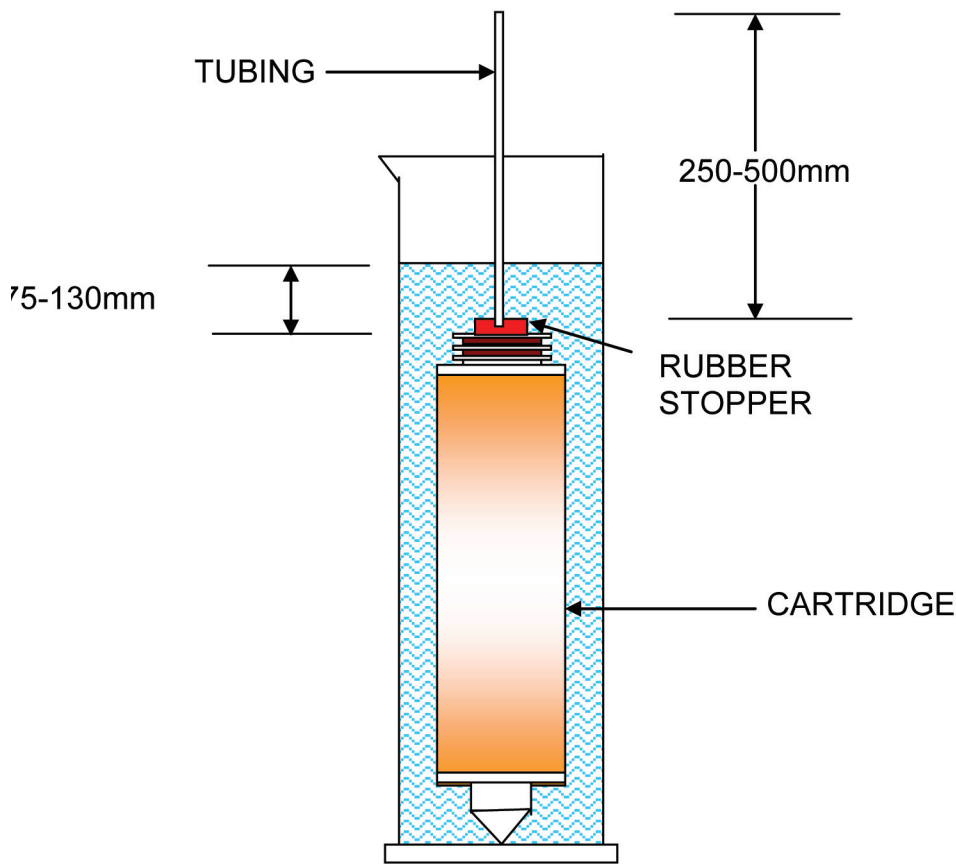

figure 1.