

# Hall Pyke



**Filter Housings**

**St steel**  
**industrial grade**

**The SMART choice for filtration**

**APPLICATIONS**

- Water
- Steam
- Nitrogen
- CO<sub>2</sub>



**FEATURES & BENEFITS**

Single Round T-Style filter housings for PED Fluid Group 1 and 2, up to 16 bar, 145 psi.

- Sockets: 226 CODE 7, 222 CODE 8, D.O.E.
- Laser etched customizable logo
- Connections: TC, BSP, NPT and Butt Weld
- Full range from 10" to 40"
- Suitable for SIP and CIP
- 316L/1.4404 Stainless Steel ensures corrosion resistance and durability
- Automated Welding Processes to guarantee consistent quality and accuracy
- Designed according to Pressure Equipment Directive (PED)
- ATEX Compliance
- Food Grade Compliance: CE 1935/2004
- Gasket Materials: FDA and USP Class VI
- Customizable with optional accessories
- User manual and declaration of conformity included
- Certificates: 3.1 EN 10204

**SELECTION CRITERIA**

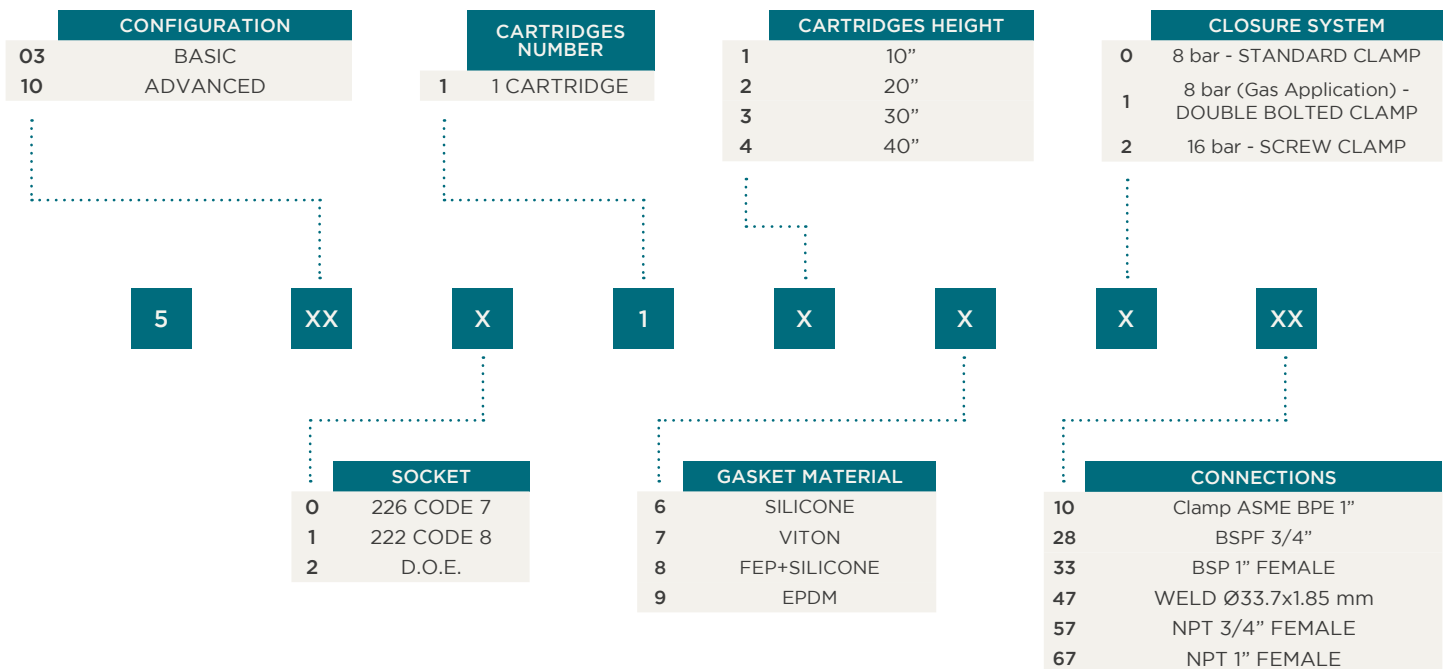

## SPECIFICATIONS

All dimensions are in mm (inches).

Socket	In/Out	L
226 CODE 7	BSP 3/4" - NPT 3/4"	126 (4.96)
226 CODE 7	BSP 1" - NPT 1" - WELD 33.7	110 (4.33)
226 CODE 7	Clamp DIN 32676 DN32	195 (7.67)
222 CODE 8 / D.O.E.	BSP 3/4" - NPT 3/4"	114 (4.48)
222 CODE 8 / D.O.E.	BSP 1" - NPT 1" - WELD 33.7	98 (3.85)
222 CODE 8 / D.O.E.	Clamp DIN 32676 DN32	183 (7.20)

## BASIC

Cartridges Height	A	C	OD
10"	41 (1.61)	382 (15.04)	88.9 (3.50)
20"	41 (1.61)	637 (25.08)	88.9 (3.50)
30"	41 (1.61)	892 (35.12)	88.9 (3.50)
40"	41 (1.61)	1147 (45.16)	88.9 (3.50)

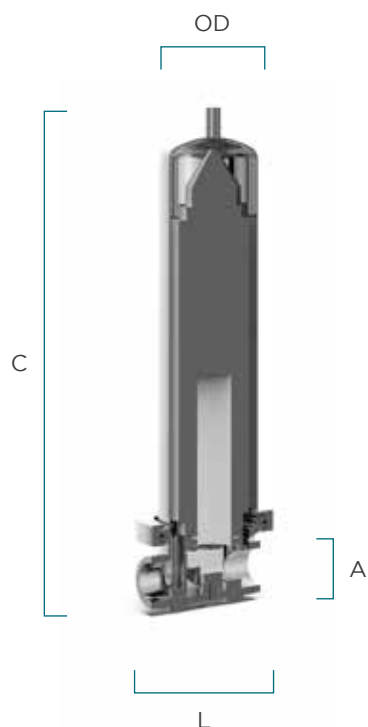

## ADVANCED

Cartridges Height	A	C	OD
10"	100 (3.93)	572 (22.51)	88.9 (3.50)
20"	100 (3.93)	827 (32.55)	88.9 (3.50)
30"	100 (3.93)	1082 (42.59)	88.9 (3.50)
40"	100 (3.93)	1337 (52.63)	88.9 (3.50)

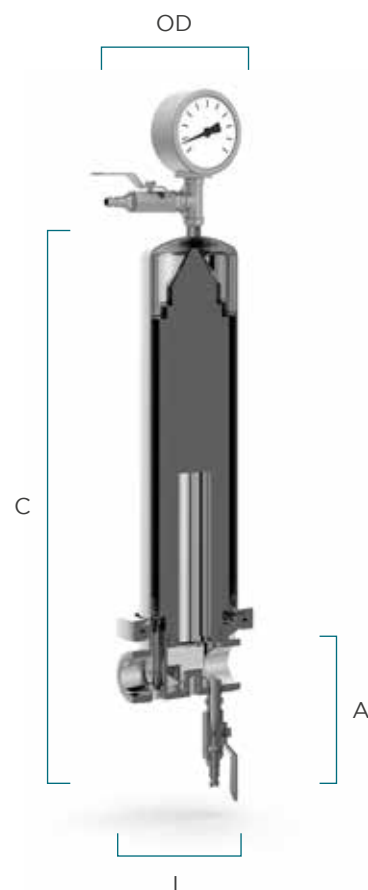

Materials of Constructions (Wetted Parts)	316L / 1.4404
No. Of Cartridges	1
Cartridge Socket	226 CODE 7, 222 CODE 8, D.O.E.
In/Out Connections	Butt Weld, BSP, Clamp ASME BPE
Drains	BSP 1/4" FEMALE
Vent	BSP 1/4" MALE
Pressure (PS) min-max	-1 ÷ 16 bar (-14 ÷ 145 psi)

Temperature (TS) min-max	-20° ÷ 150°C (-4° ÷ 302°F)
External Surface	Mirror Polishing
Internal Surface	Pickled/Mechanical Polishing
ATEX	Compliant with EU Directive
PED 2014/68/EU	Liquid and Gas, PED Fluid Group 1 and 2
Design Code	EN 13445/SEP
Housing and Gasket Materials	EU 1935/2004 - FDA - USP VI

## ACCESSORIES

Full list of accessories and spare parts available on request.



VENT GROUP	
TECHNICAL DATA	
MATERIAL	AISI 316L
GASKET MATERIAL	PETP
PRESSURE GAUGE	Ø63, GLICERINE BATH
PART NUMBERS	
601603010 (BSPF)	
89121 (NPTF)	



DRAIN VALVE	
TECHNICAL DATA	
MATERIAL	AISI 316L
GASKET MATERIAL	PETP
PART NUMBERS	
602603025 (BSPM)	
602600025 (BSPF)	
89123 (NPTM)	
89124 (NPTF)	



WALL BRACKET	
TECHNICAL DATA	
MATERIAL	AISI 316L
PART NUMBERS	
83047	

# Hall Pyke



[www.hallpyke.ie](http://www.hallpyke.ie)

Head Office, 3A Sunbury Industrial Estate, Ballymount Road, Walkinstown, Dublin 12.  
T. +353-1-4501411 F. +353-1-4507960 E. [info@hallpyke.ie](mailto:info@hallpyke.ie) W. [www.hallpyke.ie](http://www.hallpyke.ie)